



V100 Kent range of domestic
volumetric cold water meters



The world's biggest selling
domestic water meter

DMS
METERING
SOLUTIONS



elster

V100 volumetric cold water meters

The world's most successful domestic water meter. The V100's unique design offers an unparalleled blend of accuracy, durability and security.

Available in sizes from 15mm to 40mm, with flow rates of between 7.5 l/h to 20 m³/h, V100 meters offer unrivalled performance to BS5728, ISO4064 Class C or D (for 15mm to 25mm only). With over 50 million units in service, in over 100 countries, the product offers high accuracy, long-life, low maintenance and tamper-proof operation, as well as the ability to provide valuable management information via a probe pulse unit upgrade.

Easy to read

Fully-sealed and liquid-filled, the meter's counter offers simple, straight-reading presentation, and the counter window is mounted inside the meter body in the direction of flow for easy reading. The number rollers are completely immersed in a lubricating non-toxic liquid, and a sac attached to the counter casing acts as a balancing membrane to ensure equalisation of pressure between the liquid in the counter and that of the external water.



Key features

- The world's biggest selling domestic water meter
- Optimum accuracy and performance at all times, in any position
- Revolutionary grooved piston for improved durability and performance
- Durable tamper-proof construction
- Full range of sizes from 15mm to 40mm
- Water temperatures up to 50°C
- Maximum working pressure of 16 bar
- Pulse output available providing access to management information

Robust, leak-proof construction

A variety of design features contribute to the meter's leak-proof performance. The use of advanced engineering plastics for the meter's measuring chamber, for example, significantly reduces wear, while a large surface area strainer prevents solid particulate from causing damage. The advanced design of the V100 range ensures partial obstruction of the strainer does not adversely affect the accuracy of the meter's registration, and a body 'O' ring seal between the measuring chamber and meter body ensures that the possibility of internal leaks by-passing the measuring chamber are eliminated.

High accuracy in any position, for any flow

Based on the volumetric rotary piston measurement principle, the V100 range offers the very highest levels of reading accuracy, even at the lowest flow rate. Optimum accuracy is maintained whether the meter is installed horizontally, vertically or on an incline.

Tamper proof operation

The V100 offers extremely high resistance to illegal tampering through a unique design which eliminates the risk of disassembly in the field. A mechanically-driven cyclometer-type counter protects the meter from magnetic interference, and an optional return reverse flow restrictor can be used to prevent it from being operated in the reverse direction to reduce the reading. This restrictor cannot be removed without opening the meter and destroying the seal.

Powerful management information tool

V100 meters enable the collection of valuable management information, such as consumption and flow, through the use of an optional probe pulse unit. This information is available on a temporary or permanent basis, allowing analysis of consumption patterns and the ability to detect leaks early on. Volt-free probe pulsers provide output signals for interrogation by externally-powered reading devices, and can be retrofitted – at any time, and without interrupting the water supply – to any V100 meter with a probe pulse unit facility.

Reducing stoppages with the grooved piston

The relative motion of the grooved piston, with the stationary chamber wall, creates small flow eddies which hold solids in suspension until flushed out, reducing meter stoppages.

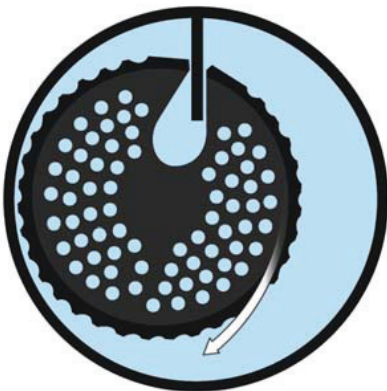

High performance, guaranteed reliability

To significantly reduce meter stoppages, enhance durability and improve performance, the V100 range features a unique grooved piston within the meter measuring chamber (available in 15mm and 20mm sizes). Every meter is manufactured from the highest quality materials to ensure maximum resistance to wear and corrosion, and is individually tested over its flow range before shipping. All Elster meters are UK WRAS approved.

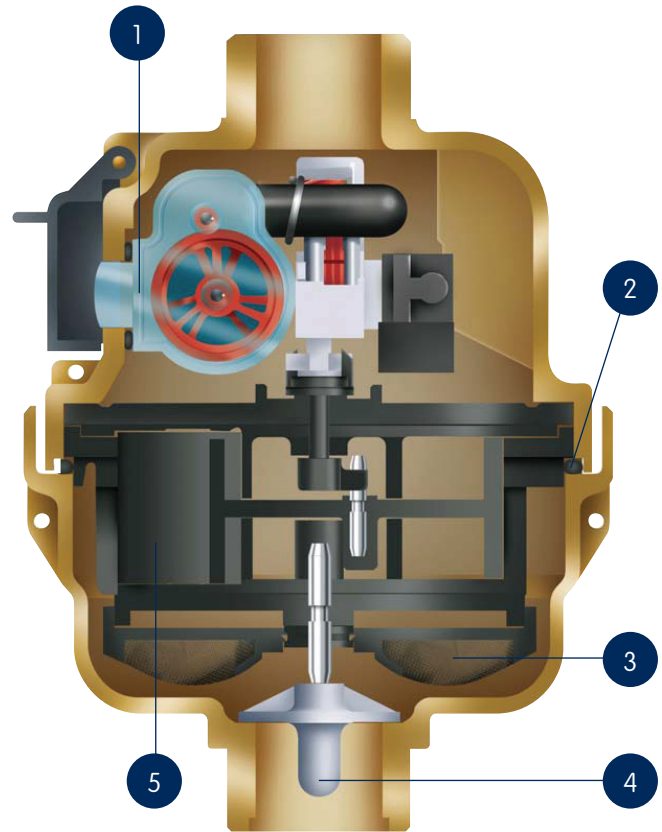

- 1 Easy to read register
- 2 'O' ring seal
- 3 Strainer
- 4 Optional non-return valve
- 5 Grooved piston design gives long working life and reduces blockage

About Elster Group

A world leader in advanced metering infrastructure, integrated metering, and utilisation solutions to the gas, electricity and water industries, Elster's systems and solutions reflect over 170 years of knowledge and experience in measuring precious resources and energy.

Elster provides solutions and advanced technologies to help utilities more easily, efficiently and reliably obtain and use advanced metering intelligence to improve customer service, enhance operational efficiency, and increase customer benefits. Elster's AMI solutions enable utilities to cost-effectively deliver, manage, and conserve the life-essential resources of gas, electricity, and water. Elster has over 7500 staff and operations in 38 countries in North and South America, Europe, and Asia.

WEEE producer identification number: WEE/EJ0221XT/PRO



www.elstermetering.com

Contacts

DMS Metering Solutions
X-Cel House
Chrysalis Way
Langley Bridge
Eastwood
NG16 3RY

Tel.: 01773 534555
Fax: 01773 534666
Email: sales@dmsltd.com
Web: www.dmsltd.com

© 2014 by Elster Water Metering Ltd. All rights reserved. The company's policy is one of continuous product improvement and the right is reserved to modify the specifications contained herein without notice.

Lit Ref: 8514A1250