

Superstatic 749

Fluidic Oscillation Compact Heat Meter



Application

The **Superstatic 749** is an autonomous compact thermal energy meter consisting of a flow meter an integrator and a pair of temperature sensors.

It's used in home automation, local and district heating/cooling systems to measure the consumption of heating or cooling energy for the individual heat cost billing. It's made to measure lower flows and energies.

The compact thermal energy meter **Superstatic 749** meets the requirements of the European directive 2004/22/EC (MID) and the standard EN 1434 class 2.

The **Superstatic 749** is designed on the basis of the proven **fluid oscillation** principle used exclusively by **Sontex**. Due to the use of a static flow sensor, the heat meter **Superstatic 749** does not have any moving parts and thus no wear. The fluid oscillation principle guarantees a high stability and repeatability for a reliable and precise measurement of flow and thermal energy.

The heat and cooling meter **Superstatic 749** consists of a new static fluid oscillator flow sensor for flows from q_p 0.6 – 2.5 m³/h, in permanent connection with a new removable integrator and a pair of temperature sensors covering an operation range from 5°C – 90°C.

The **Superstatic 749** can be used for the measurement of heating energy, cooling energy or a combination of heating / cooling energy in the temperature range of 5°C – 90°C. Through its two additional optional pulse inputs, it is possible to connect, e.g., two water meters (hot and cold) and read them remotely via the heat meter.

Main features

The heat and cooling meters **Superstatic 749** are optimized for the measurement and calculation of energy consumption in district or local heating systems.

- For flows of q_p 0.6 – 2.5 m³/h
- Corrosion resistant materials
- No moving parts, thus no wear
- Not sensitive to dirt
- Stable
- Direct pick-up of voltage pulses without reflectors
- Long-term stability, accurate and reliable measurement
- Easy to operate and read
- Non-volatile EEPROM memory
- 18 monthly energy values for heat energy, volume, cooling energy and for the additional pulse inputs 1 and 2 and for the set day values
- The **Superstatic 749** is suitable for all communication environments:
 - Optical interface, self-powered M-Bus, bi-directional radio, Wireless M-Bus (OMS compatible) and two pulses output
- Two pulses inputs
- Self-monitoring of conditions

Variants

The **Superstatic 749** is available in the following variants:

- Flow meter from q_p 0.6 m³/h, q_p 1.5 m³/h, q_p 2.5 m³/h with
- **Standard product :**
 - Heat meter MID, temperature sensors Ø 5 mm, 1.5m
 - Optical interface
 - Battery 6+1 years

Options Superstatic 749

| | | | | | | | | | | | | | | | | | | | |
|--|---|---|---|---|----|---|---|---|---|---|---|---|---|---|---|---|----|---|---|
| Temperature sensor Ø 5,2 mm, Ø 6 mm | ■ | ■ | ■ | ■ | ■ | ■ | ■ | ■ | ■ | ■ | ■ | ■ | ■ | ■ | ■ | ■ | ■ | ■ | ■ |
| Battery 12+1 years | ■ | | ■ | ■ | ■ | | ■ | ■ | ■ | ■ | | ■ | ■ | ■ | ■ | | ■ | ■ | ■ |
| Self-powered M-Bus | | ■ | | | | | ■ | | | | | ■ | | | | | ■ | | |
| Radio Supercom | | | ■ | | | | | ■ | | | | | ■ | | | | | ■ | |
| Wireless M-Bus (OMS) | | | | ■ | | | | | ■ | | | | ■ | | | | | | ■ |
| 2 Pulses outputs | | | | | *■ | | | | | | | | | | | | °■ | | |
| 2 Pulses inputs | | | | | | ■ | ■ | ■ | ■ | ■ | | | | | | ■ | ■ | ■ | ■ |
| Cooling or Heating / cooling | | | | | | | | | | | ■ | ■ | ■ | ■ | ■ | ■ | ■ | ■ | ■ |

- * Thermal version: Heat energy and volume
- ° Heating / cooling version: Heat and cool energy

Functions

- Recording heat or heat/cool consumption by means of measuring the flow and temperature difference.
- Configuration of the two additional pulse inputs through the optical interface, M-Bus or by radio
- Displaying consumption data:
 - Displaying 18 monthly energy and volume values
 - Displaying 18 monthly cooling energy
 - Displaying 18 monthly values of additional pulse input 1
 - Displaying 18 monthly values of additional pulse input 2
 - Set day values
 - Displaying operating data
 - Self-monitoring with error display

Fluid oscillation flow sensor: The principle

Picture 1: The liquid passes through a special insert, the oscillator. Before passing the oscillator, the liquid is led to a nozzle and accelerated to a jet (oscillating jet). Opposite of the nozzle, the jet is redirected to the left or right into a channel. Due to the differential pressure generated in the channel, part of the liquid flows to the piezo-sensor above and part flows back to the pipe. The pressure of the liquid on the piezo-sensor generates an electrical pulse. Thus the liquid flows back to the pipe through a return loop and redirects the jet into the other channel where the action is repeated and fluid oscillation is created.

Picture 2: The animated top view on the oscillator shows the differences in velocity of the liquid: The oscillation jet accelerated by the nozzle with the highest velocity in red, slow velocity in blue.

The electrical pulses generated by the piezo-sensor with differential pressure correspond to the movement, the frequency of the jet. The electrical pulses are processed, amplified and filtered by the electronics. The electrical pulses are recorded by the integrator connected with the flow sensor and converted into flow. The frequency of the oscillation jet, i.e. the electrical pulse, is proportional to the flow.

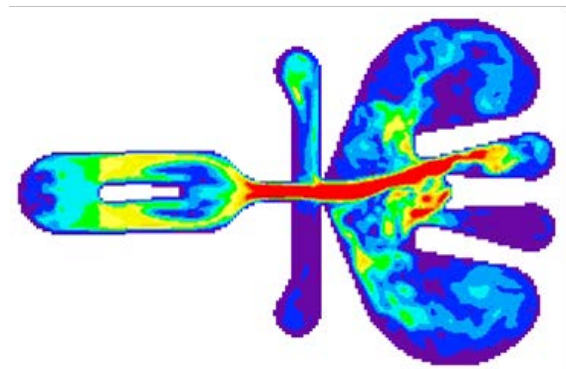
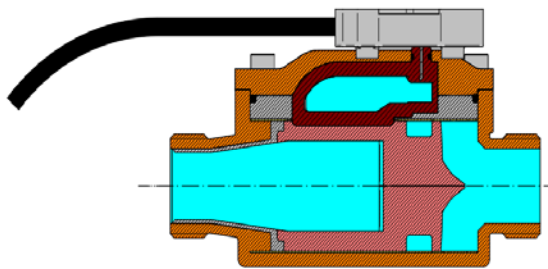

→ Flow direction

Picture 1: Section through the flow sensor

Picture 2: Schematic of oscillator with oscillating jet (RED)

Temperature sensors

The pair of temperature sensors Pt 1'000 is connected to the integrator and is an integral part of the heat meter. By default the cold side sensor is mounted (and sealed) in the flow sensor.

The temperature sensors mustn't be changed or modified.

Integrator

The integrator is equipped with a large 8-digits display and can be rotated by 360°. The integrator can be separated from the flow sensor and be installed separately. A cable of 0,6 meter connects the integrator to the flow sensor. The housing of the integrator got a protection degree of IP65 against dust and humidity.

Display

The LCD display of the **Superstatic 749** has a large, clear design and high contrast, making it easy to read the data.

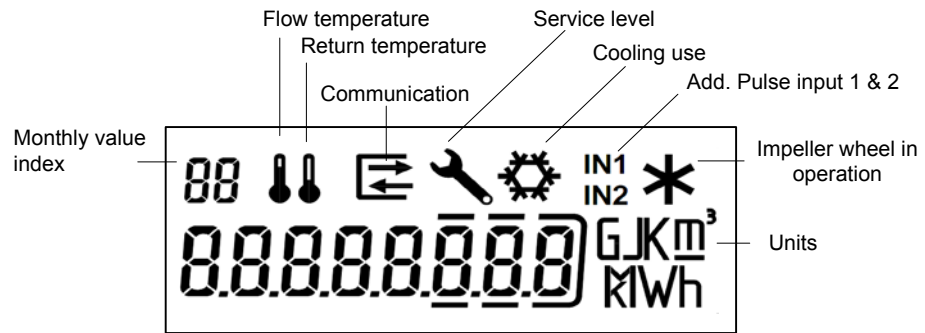

Display sequences

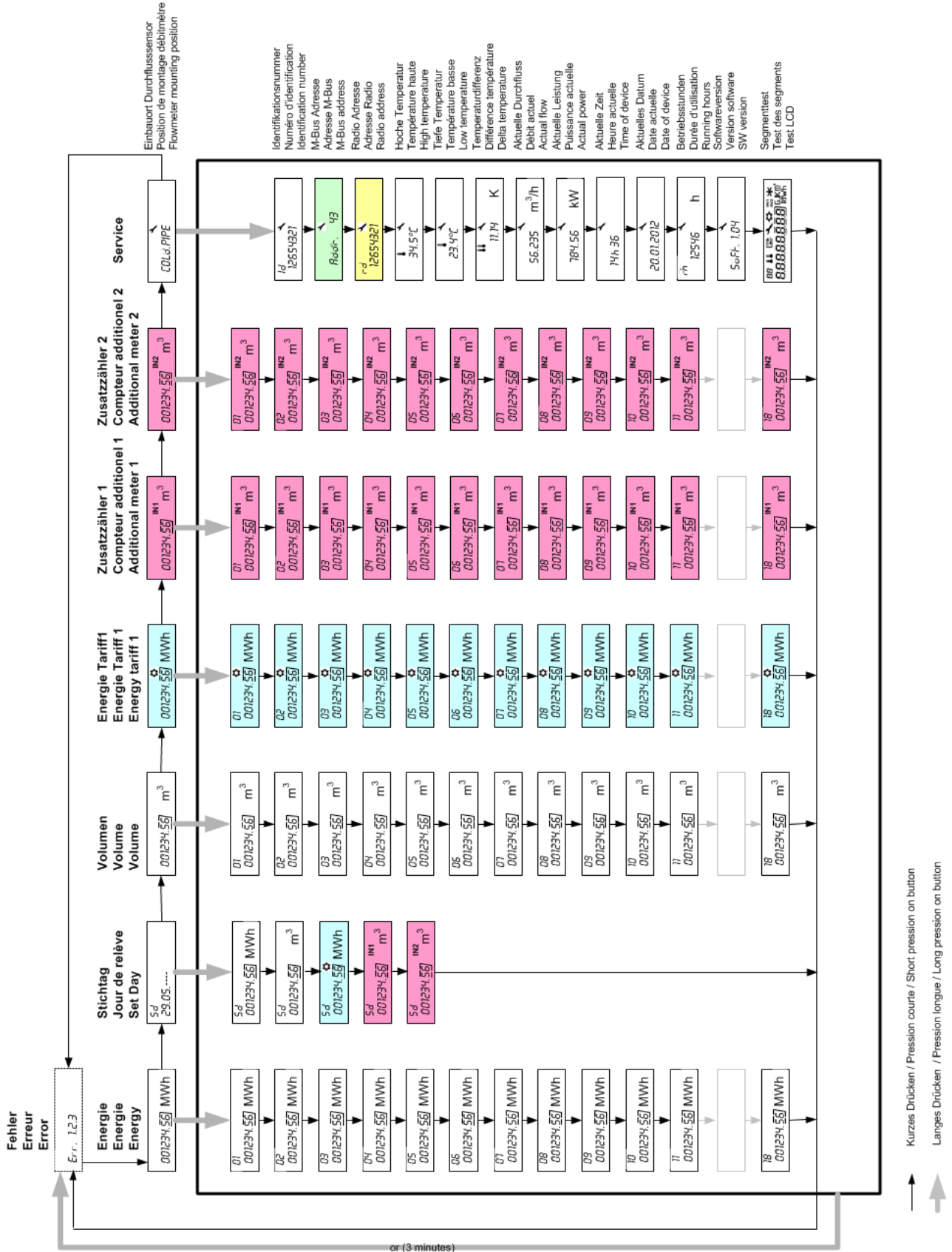

Error messages

| | |
|-------|---|
| Err 1 | Flow higher than 1.2 x qs or faulty flow sensor. |
| Err 2 | Measured temperature out of range or faulty temperature sensor. |

Energy calculation

The flow sensor records the flow. Using a microprocessor, the integrator calculates the temperature difference and calculates the thermal energy, respectively the heating/cooling energy, consumed using the average flow and the heat coefficient.

Solar- and cooling installations

The Superstatic 749, calibrated for water ensure also with glycol mixtures a precise measurement, as the average mixing ratio can customized over the optical interface. The Superstatic 749 processes and computes also negative temperatures. The dust proof and splash water-protected housings, IP65, is especially suitable for cooling installations. For these customized mixing ratios no official approvals are possible. The integrator has programmed more than 60 different cooling medium and countless coolant-water mixtures can also be defined by software.

Cooling energy

The cooling energy is stored in another memory than the heat energy and will be cumulated only if the two following conditions are fulfilled:

- (Δt) Temperature difference > -0.5K
- Supply temperature < 18°C

The threshold value of the temperature is set by default at 18°C. If necessary, the threshold value can be incremented in steps of 1°C using the optical head. The cooling energy has the same physical unit as the heat energy. If the calculator is used for the combined heating/cooling measurement, the cooling power and the temperature difference are displayed with a minus sign (-) and the values will be stored in the Tariff 1 register.

Non-volatile memory

The device parameters, as well as the cumulative values for energy and volume, cooling energy, monthly values, set day values, values of the pulses input counters 1 and 2, operating hours and error type are stored in a non-volatile memory (EEPROM), where they are saved even in case of a power failure (e.g. changing batteries). Once an hour and in the event of battery failure, the cumulative values are updated in the EEPROM.

Monthly values

At the end of each month, the monthly values are stored. A total of 18 monthly values of heat energy, volume, cooling energy and of the additional pulses inputs 1 and 2 are memorized in the integrator.

Pulse inputs

As an option the **Superstatic 749** offers the possibility to integrate beneficially up to two additional pulse inputs such as a hot and cold water meter.

Communication options

Several communication interfaces are available (see the options table). The configuration of the communication option of the **Superstatic 749** can be carried out with the free software Prog7X9 available from Sontex.

TECHNICAL DATA SUPERSTATIC 749

The integrator

Temperature sensors

| | |
|-------------------------------------|---------------------|
| Temperature sensor 2 wires | Pt1'000 |
| Diameter | Ø5.0; Ø5.2, Ø6.0 mm |
| Cables length | 1.5 m |
| Admissible range | 0...110°C |
| Differential range | 3...75 K |
| Response limit | 0.5 K |
| Temperature resolution (display) | 0.1 K |
| Temperature resolution Δt | 0.01 K |
| Measurement cycle for temperature | from 10 seconds |
| Measurement cycle for flow * | Permanently |

* The oscillating measurement principle and the differential pressure piezo sensor ensures at any time that all pulses, ie, all volume is detected. In contrary to the ultrasonic measuring principle, no scanning with a signal through the water is necessary.

Environment class

| | |
|---|------------|
| Environment class | C |
| Mechanics | M1 |
| Electronics | E1 |
| Battery protection class | III |
| Cable connection between flow sensor and integrator | 0.6 m, fix |
| Protection index | IP 65 |

Permissible temperature

| | |
|--------------------------|------------|
| Operation | 5...55°C |
| Operation: radio version | 5...40°C |
| Storage and transport | -10...60°C |

Display

8-digits LCD

Display units

| | |
|--------------------------|------------------|
| Energy | kWh, MWh, MJ, GJ |
| Volume | m ³ |
| Additional pulse inputs: | Volume or pulses |
| Temperature | °C |
| Δ Temperature | K |

Power supply

| | |
|--------------------|-------------------|
| Lithium battery 3V | 6+1 or 12+1 years |
|--------------------|-------------------|

Powered by M-Bus line

1 device = 2 M-Bus charges (max 2 x 1.5mA)

Pulse output

| | |
|---|--------------|
| Open drain (MOS Transistor) | 1 Hz, 500 ms |
| $V_{CC_{max}}$: 35 V _{DC} ; $I_{CC_{max}}$: 25mA | |

Pulse inputs with a dry contact

| | |
|------------------------------------|---|
| Power supply _{internal} | 2.3 V _{DC} |
| $R_{pull\ UP}$ _{internal} | 2 M Ω |
| Pulse factor | 0...999.999 m ³ /Imp or without unit |

Fluidic Oscillation Flow Sensor

| qp | Threaded connection | | Mounting length | Mat. | PN | Maximal flow qs | Minimal flow qi | Low flow threshold value (50°C) | Threaded hole for sensor | Weight | Kvs value (20°C) | Pressure loss at qp |
|-------------------|---------------------|------|-----------------|-------|-----|-------------------|-----------------|---------------------------------|--------------------------|--------|-------------------|---------------------|
| m ³ /h | G" | DN | mm | | bar | m ³ /h | l/h | l/h | | kg | m ³ /h | bar |
| 0.6 | 3/4" | (15) | 110 | Brass | 16 | 1,2 | 6 | 4 | Yes | 1.2 | 1.4 | 0.19 |
| 1.5 | 3/4" | (15) | 110 | Brass | 16 | 3 | 15 | 10 | Yes | 1.3 | 3.4 | 0.2 |
| 1.5 | 1" | (20) | 130 | Brass | 16 | 3 | 15 | 10 | Yes | 1.4 | 3.4 | 0.2 |
| 1.5 | 1" | (20) | 190 | Brass | 16 | 3 | 15 | 10 | Yes | 1.6 | 3.4 | 0.2 |
| 2.5 | 1" | (20) | 130 | Brass | 16 | 5 | 25 | 17 | Yes | 1.4 | 5.7 | 0.19 |
| 2.5 | 1" | (20) | 190 | Brass | 16 | 5 | 25 | 17 | Yes | 1.6 | 5.7 | 0.19 |

16 bar = 1.6 MPa

Pressure loss curve

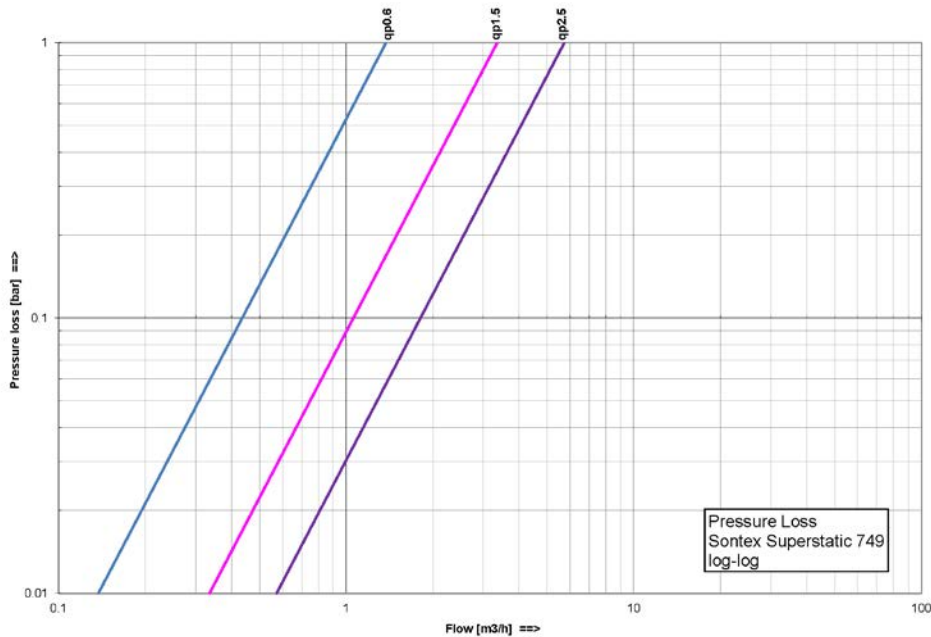

Metrological class

EN 1434 class 2

Mounting

Long term operating temperature 5°C - 90°C
 Straight pipe section in front of the flow sensor for installation lengths 110 mm (acc. EN 1434) 3D
 Straight pipe section in front of the flow sensor for installation length 130 mm and 190 mm (acc. EN 1434) 0D

Flow sensor protection index

IP 68

Dimensions

| | qp 0.6 m ³ /h | qp 1.5 m ³ /h | qp 2.5 m ³ /h |
|----------------------------------|--------------------------|--------------------------|--------------------------|
| Mounting length [L] | 110 mm | 110/130/190 mm | 130/190 mm |
| Integrator | 110.2 x 86.8 mm | 110.2 x 86.8 mm | 110.2 x 86.8 mm |
| Total height | 105.0 mm | 110.5 mm | 108.0 mm |
| Height from the axis of the tube | 87.5 mm | 90.0 mm | 87.5 mm |
| Height without integrator | 52.0 mm | 54.5 mm | 52.0 mm |

qp 0.6 m³/h
(L: 110 mm)

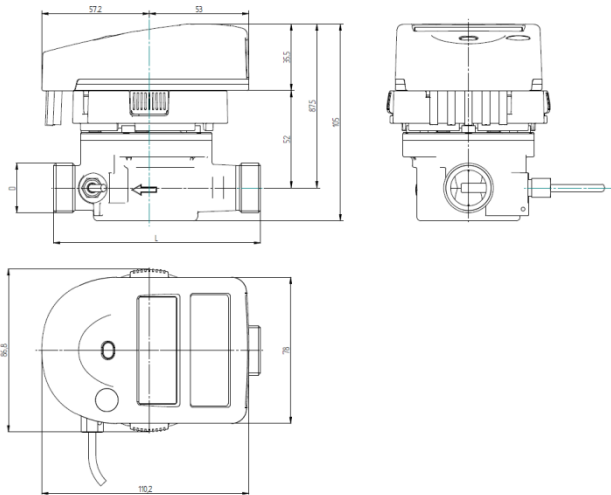

qp 1.5 m³/h
(L: 110/130/190 mm)

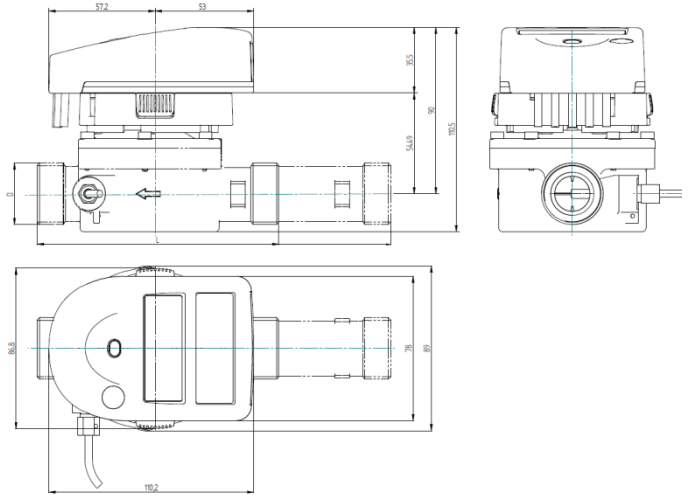

qp 2.5 m³/h
(L: 130/190 mm)

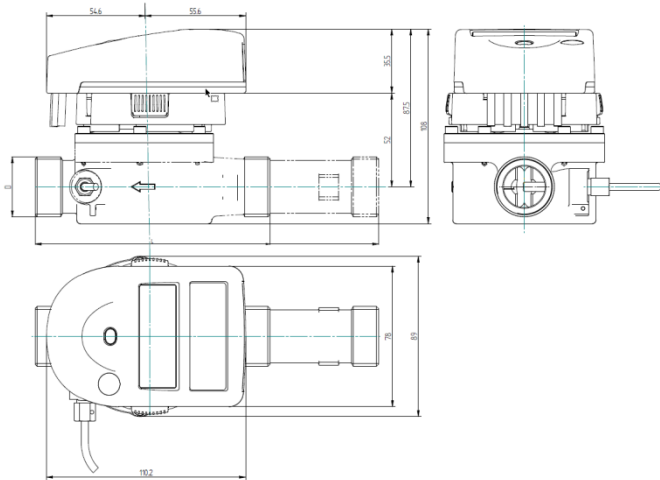

Superstatic 749, qp1.5, 190 mm

Technical Support

For technical support, please contact your local Sontex agent.

| | |
|------------------------|---|
| DMS Metering Solutions | Tel.: 01773 534555 |
| X-Cel House | Fax: 01773 534666 |
| Chrysalis Way | Email: sales@dmsltd.com |
| Langley Bridge | Web: www.dmsltd.com |
| Eastwood | |
| NG16 3RY | |

CE conformity according to

Directive 2004/22/EC (MID)
R &TTE guideline 1999/5/EC

The detailed declaration of conformity can be provided, please contact your local Sontex agent.

Modifications subject to change without notice

Data Sheet Superstatic 749 EN 01-08-2015

© Sontex SA 2013