

## Superstatic 449

### Static Heat Meter, Static Cooling Meter



#### Application

The **Superstatic 449** is a battery- or mains powered static compact heat meter. It is used in building automation or in district or local heating to record the consumption-dependent thermal or cooling energy for the billing of thermal energy consumption costs. It covers the range of lower flow rates and energy quantities. The **Superstatic 449** meets the requirements of the European guideline MID-2004/22/EC and the standard EN 1434 class 2.

The **Superstatic 449** is designed on the basis of the proven **fluid oscillation** principle used exclusively by **Sontex**. Due to the use of a static flow sensor, the heat meter **Superstatic 449** does not have any moving parts and thus no wear. The fluid oscillation principle guarantees a high stability and repeatability for a reliable and precise measurement of flow and thermal energy.

The **Superstatic 449** can be used in the following fields:

- Thermal heat energy
- Energy for the production of cooling energy with water

#### Design

The heat and cooling meter **Superstatic 449** consists of a completely newly developed static fluid oscillator flow sensor for flows of  $q_p$  1.5 – 2.5 m<sup>3</sup>/h, in permanent connection with the integrator and an interchangeable pair of temperature sensors Sontex 460. Consumption values can easily be read over the LCD display, an optical interface, over the **Supercom** radio, M-Bus and LON or many other common interfaces.

**Temperature sensor pair**

The temperature sensors and the integrator are available as Pt 500 or Pt100 version. The temperature sensors are paired. They are always supplied in pairs and must not be separated, extended or shortened.

**Measurement technology**

The integrator with mains power supply records every 3 seconds the supply and return temperature, with battery power every 30 seconds (D-type battery). The recording of the flow is dependent on the pulse values of the flow sensor and is constantly updated. With the average flow rate, the temperature difference as well as the heat coefficient the energy of the captured medium is calculated and displayed on the 8-digit LCD display.

**Fluid oscillation flow sensor: The principle**

Picture1: The liquid passes through a special insert, the oscillator. Before passing the oscillator, the liquid is led to a nozzle and accelerated to a jet (oscillating jet). Opposite of the nozzle, the jet is redirected to the left or right into a channel. Due to the differential pressure generated in the channel, part of the liquid flows to the piezo-sensor above and part flows back to the pipe. The pressure of the liquid on the piezo-sensor generates an electrical pulse. Thus the liquid flows back to the pipe through a return loop and redirects the jet into the other channel where the action is repeated and fluid oscillation is created.

Picture 2: The animated top view on the oscillator shows the differences in velocity of the liquid: The oscillation jet accelerated by the nozzle with the highest velocity in red, slow velocity in blue.

The electrical pulses generated by the piezo-sensor with differential pressure correspond to the movement, the frequency of the jet. The electrical pulses are processed, amplified and filtered by the electronics. The electrical pulses are recorded by the integrator connected with the flow sensor and converted into flow. The frequency of the oscillation jet, i.e. the electrical pulse, is proportional to the flow.

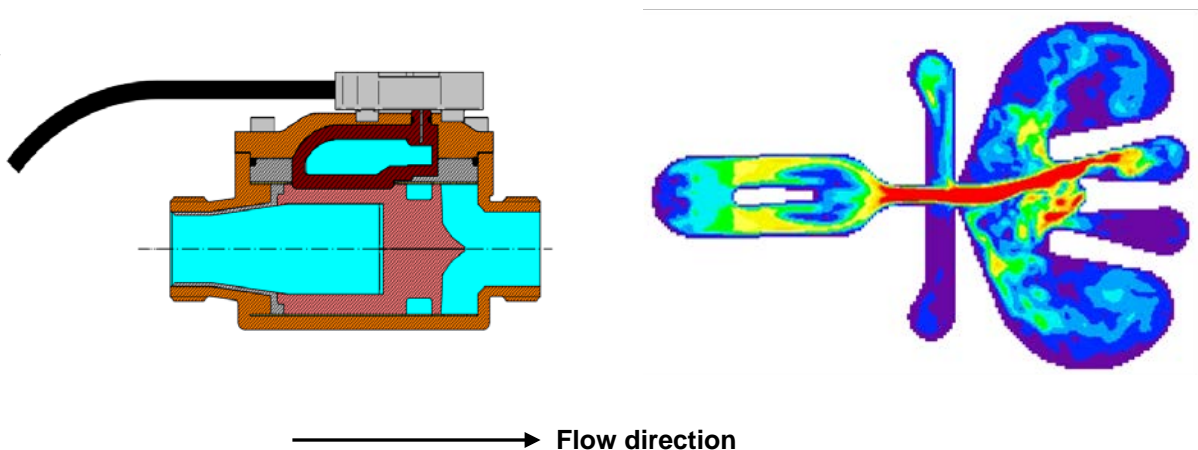

Picture 1: Section through the flow sensor

Picture 2: Schematic of oscillator with oscillating jet (RED)

## Main features

The heat and cooling meters **Superstatic 449** are optimized for the measurement and calculation of energy consumption in district or local heating systems. They are also very well suited to use purely as volumetric flow meter for various media.

- For flows of  $q_p$  1.5 – 2.5 m<sup>3</sup>/h
- Purchase and maintenance costs are reasonable compared with other static flow sensors
- Corrosion resistant materials
- Threaded fittings
- No moving parts, thus no wear
- Not sensitive to dirt
- Stable
- Dynamic range 1 : 100 at  $q_p$  1 – 2.5 m<sup>3</sup>/h
- Direct pick-up of voltage pulses without reflectors
- Medium-independent measurement possible
- Long-term stability, accurate and reliable measurement

## Integrator

The integrator, as part of the heat meter **Superstatic 449**, is suitable for connecting Pt 500 or Pt 100 temperature sensor pairs with 2- or 4-conducting wire technology. The **additional pulse inputs allow the connection of hot water, cold water, gas, oil and electricity meters**. The consumption values can easily be read on the LCD display, via the optical interface, RS-232, M-Bus, **Supercom** radio, GSM or LON module etc.

## Power supply

The flexible power supply concept of the integrator allows the following combinations:

- D-type battery: 11+1 year
- 230 V AC 50/60 Hz
- 24 V AC 50/60 Hz
- 12...24 V DC

## Interfaces

All versions can be ordered with two optional galvanically separated communication modules or be equipped at a later date when the integrator is in operation and this without compromising verification:

- Optical (standard)
- RS-232
- RS-232 with two additional relay outputs
- Relay module
- M-Bus module (factory assembly or post-assembly)
- M-Bus module with two additional relay outputs
- Analogue module with 2 outputs 4-20mA
- Analogue module with two outputs 0-20mA or 4-20mA or 0-10V
- Supercom radio module, bi-directional, 433 MHz (factory assembly)
- LON module

## Data storage

The integrator has two non-volatile EEPROMs for extensive data storage in case of power failure. In both EEPROMs, the data are updated every hour. The first non-volatile memory is located on the printed circuit board inside the relevant calibration and measurement part of the integrator and stores the following data:

- Integrator configuration parameters
- Cumulated energy
- Cumulated volume
- Customer-specific tariff
- 15 monthly values
- 32 maximum values
- 32 average values
- Two set days
- Cumulated energy and volume at set day
- Operating hours
- Date and time
- MET serial number (integrator upper part, calibration and measurement relevant part)
- Pulse value of the flow sensor

The second non-volatile memory is located on the printed circuit board in the integrator base part and stores the following parameters:

- MIO serial number (integrator base part, printed circuit board)
- Identification number and customer number
- Pulse value of additional meters 1 and 2
- Cumulated values of additional meters 1 and 2
- Unit of additional meters 1 and 2
- M-Bus address (primary and secondary) and radio address
- Baud rate (M-Bus)
- Pulse value of the pulse output
- Parameter setting of the analogue outputs
- Alarm and threshold values

This EEPROM guarantees a smooth exchange of the calibration and measurement relevant part without having to newly enter the configuration of the communication.

## Supply and return temperature

The temperatures are displayed with one decimal. Temperatures below 0°C are shown with a – (minus) sign. The display range is –20...200°C. Upon request, the temperature can also be displayed in °F.

## Set day values

The integrator has two set days. On the set day, the cumulated energy, volume, tariff values and additional pulse inputs are stored.

### Solar- and cooling installations

The integrator units, calibrated for water ensure also with glycol mixtures a precise measurement, as the average mixing ratio can be customized over the optical interface. The Superstatic 449 processes and computes also negative temperatures. The dust proof and splash water-protected integrator housings, IP65, is especially suitable for cooling installations. For these customized mixing ratios no official approvals are possible.

The integrator Superstatic 449 has programmed more than 60 different cooling medium and countless coolant-water mixtures can also be defined by software.

### Cooling energy

The cooling energy is cumulated if the two following conditions are fulfilled at the same time:

- $(\Delta t)$  Temperature difference > -0.2K,
- and supply temperature < 18°C

The threshold value of the temperature is set at the factory at 18°C. The threshold value can be modified in steps of 1°C via the optical interface with the SW Prog449. The cooling energy has the same physical unit as the heat energy. If the integrator is used for the combined heating and cooling measurement, the cooling energy, the cooling power and the temperature difference are displayed with a minus (-) and the appropriate values are assigned to tariff 1.

For detailed information on the integrator, we refer you to the data sheet Supercal 531 EN of the related integrator Supercal 531.

**TECHNICAL DATA SUPERSTATIC 449**

**Dimensions**

Integrator

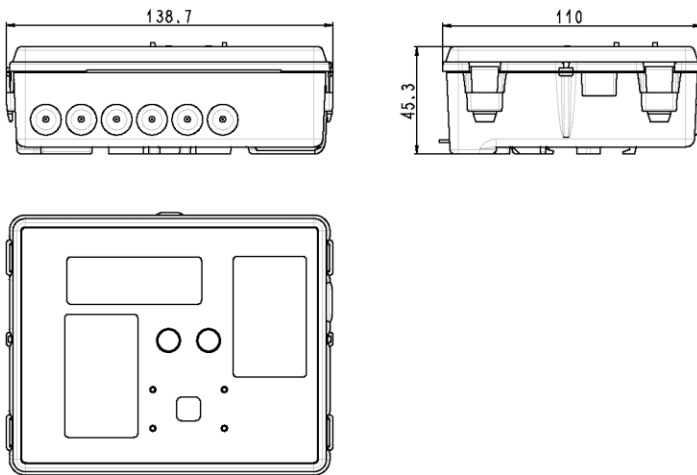

Fluid oscillator flow sensor

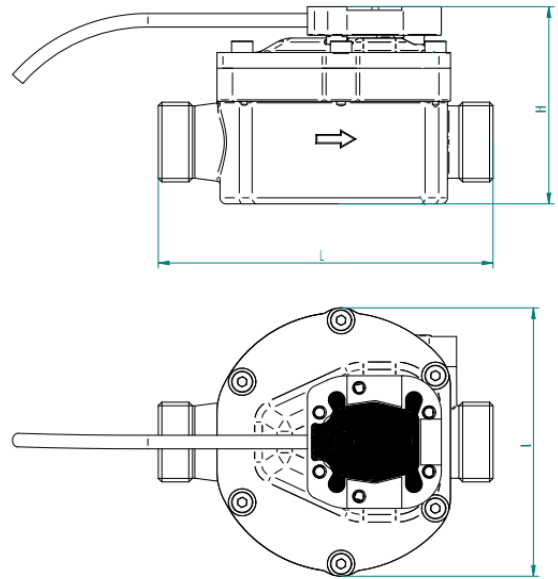

qp	G	PN	l (mm)	H (mm)	L(mm)
1.5 m <sup>3</sup> /h	3/4"	16	89	65	110
1.5 m <sup>3</sup> /h	1"	16	89	65	130
1.5 m <sup>3</sup> /h	1"	16	89	65	190
2.5 m <sup>3</sup> /h	1"	16	89	65	130
2.5 m <sup>3</sup> /h	1"	16	89	65	190

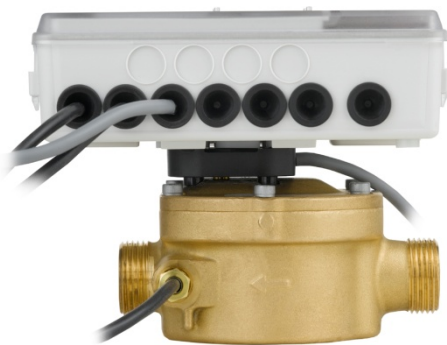

**Overview of nominal sizes**

qp	Thread connection		Length	Mat.	PN	Maximum flow qs	Minimum flow qi	Low flow threshold value (50°C)	Threaded hole for sensor	Weight	Kvs value (20°C)	Pressure loss at qp
	G"	DN										
1.5	(EN ISO 228-1) 3/4"	(15)	110	Brass	16	3	15	10	Yes	1.3	3.4	0.2
1.5	1"	(20)	130	Brass	16	3	15	10	Yes	1.4	3.4	0.2
1.5	1"	(20)	190	Brass	16	3	15	10	Yes	1.6	3.4	0.2
2.5	1"	(20)	130	Brass	16	5	25	17	Yes	1.4	5.7	0.19
2.5	1"	(20)	190	Brass	16	5	25	17	Yes	1.6	5.7	0.19

**Installation**

Permanent temperature	90°C
Straight pipe section in front of the flow sensor for installation lengths 110 mm (acc. EN 1434).	3D
Straight pipe section in front of the flow sensor for installation length 130 mm and 190 mm (acc. EN 1434)	0D
Connection between flow sensor and integrator	0.8 m; fix

**Pressure loss curve**

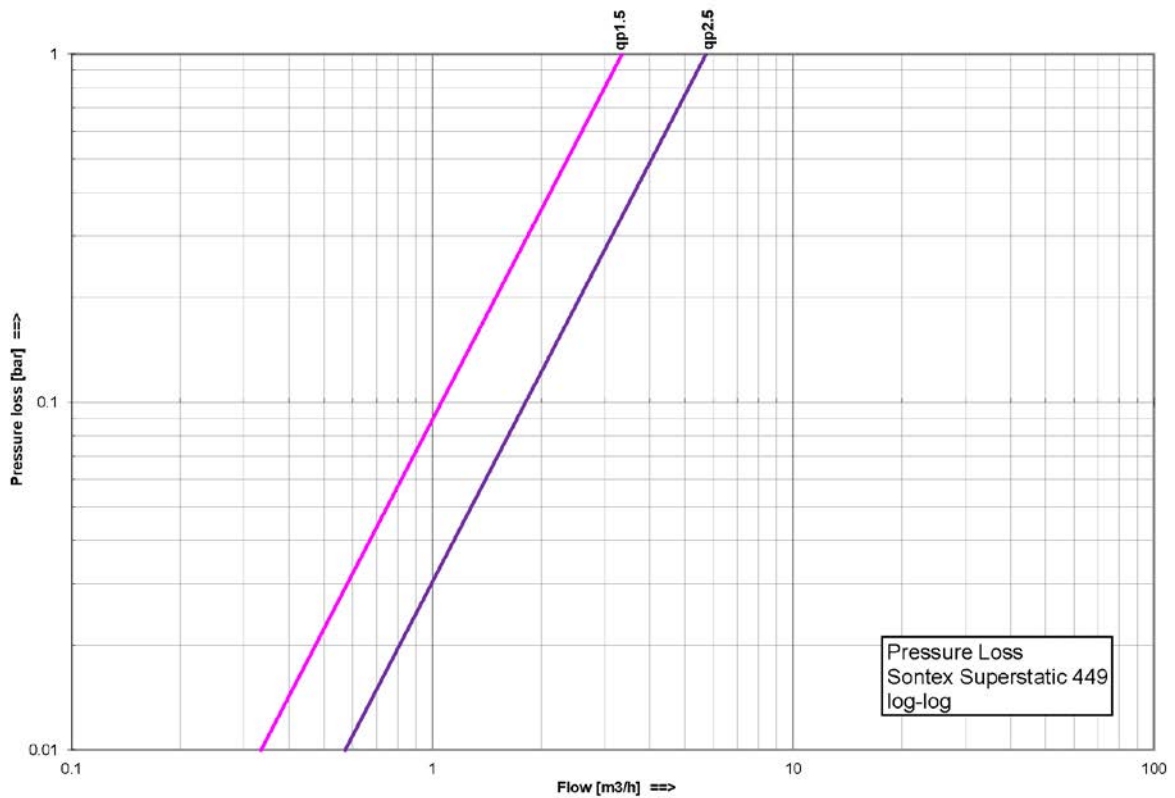

**Integrator of the Superstatic 449**

**Temperature measurement**

Pt100 or Pt500	
2- and 4-wire conducting technology	
Absolute temperature range	-20...200°C
or	
Admissible range	2...200°C
Absolute temperature difference	1...150K
Admissible range	3...150K
Response limit	0.2 K
Temperature resolution t (display)	0.1 K
Temperature resolution $\Delta t$	0.01 K
Measuring precision	EN1434 class 2

**Measurement cycle for flow \***

**Permanently**

\* The oscillating measurement principle and the differential pressure piezo sensor ensures at any time that all pulses, ie, all volume is detected. In contrary to the ultrasonic measuring principle, no scanning with a signal through the water is necessary.

**Environment class:**

Mechanics	M1
Electronics	E1

**Measuring cycles of temperature measurement:**

30 seconds when battery-operated
3 seconds when mains-operated

**Ambient temperatures**

Operation	5...55°C
Storage and transport	-20...70°C

**Display**

8-digit LCD display

**Display units**

Energy	kWh, MWh, MJ, GJ
Volume	m <sup>3</sup> , US Gallon
Additional pulse inputs	volume, energy or pulse
Temperature	°C or °F
$\Delta$ Temperature	K or °F

**Power supply**

Modular optional	
D-type battery	11 + 1 year
Mains	230 V AC – 50/60 Hz
Mains	24 V AC 50/60 Hz or 12..24 V DC

**Housing protection**

Flow meter	IP 68
Integrator	IP 65





### Technical Support

For technical support, please contact your local Sontex agent.

DMS Metering Solutions  
X-Cel House  
Chrysalis Way  
Langley Bridge  
Eastwood  
NG16 3RY

Tel.: 01773 534555  
Fax: 01773 534666  
Email: sales@dmsltd.com  
Web: www.dmsltd.com

**CE conformity according to**  
Directive 2004/22/EG (MID)  
R &TTE guideline 1999/5/EG

Detailed declarations of conformity can be found on our homepage: [www.sontex.ch](http://www.sontex.ch)

Modifications subject to change without notice

Data Sheet Superstatic 449 EN 01-08-2015

© Sontex SA 2011